

# VIKING PRO XL

## COMMERCIAL FLUIDROWER

The FDF Viking Pro XL FluidRower is a performance heavyweight in the commercial rowing market. Defined by its huge Fluid Resistance range provided by our patented Twin Tank [XL] system, this commercial rower will excel under extreme power - bringing a resistance challenge to even the fittest individual.

Bringing 50% greater Fluid Resistance from our XL Twin Tank, with ten distinct levels of adjustment, the Viking Pro XL delivers a true to life stroke with the sensory satisfaction of rowing on water. The range of adjustability from “feather light to Olympic challenge” redefines the opportunities for a work out on a rowing machine.

The highest quality, ethically sourced American Ash wood wraps around to construct the Viking Pro XL frame, it has subtle clean lines rolled up in a robust commercial machine with all the features to make it a high demand machine in any member facility.

For such an over performer, this machine boasts a compact footprint and can be stored on end with ease. It's also compatible with FDF's optional Seat Back Kit for extra lumbar support, and the Elevate Kit for easier on-off access.

# FLUID ROWER



MINIMUM



MAXIMUM

AMERICAN ASH  
WOOD FRAME

Industrial nylon belt for smooth and quiet rowing

Bluetooth monitor

Textured seat to prevent slipping

Premium ergonomic contoured handle

Transport wheels

Height adjustable footplate

Hand-lacquered American Ash wooden frame

Seat rail brushes wipe away grit protecting seat rail

Double sealed precision aligned twin fluid resistance tank

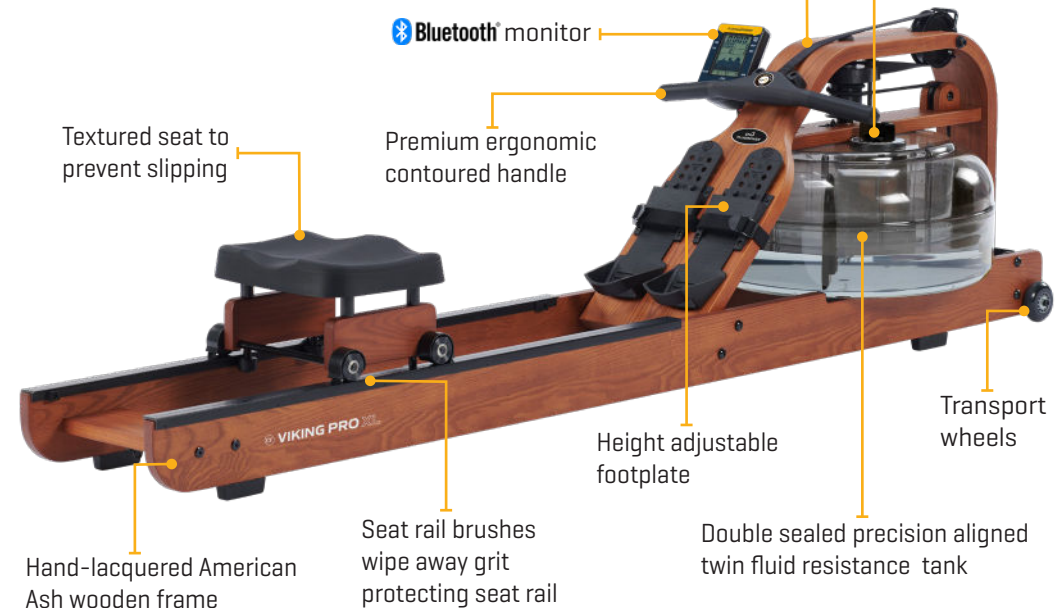

View the full range of rowers at [FLUIDROWER.COM](https://www.fluidrower.com)

Visit [FIRSTDEGREEFITNESS.COM](https://www.firstdegreefitness.com) to view all FDF product ranges.

# VIKING PRO XL FLUIDROWER

## PRODUCT SPECIFICATIONS

PRODUCT MODEL NO:	VKPX
FLUID RESISTANCE:	FDF Horizontal XL Twin Tank - 10 Levels
MONITOR:	FDF Bluetooth/ Heart Rate Compatible
PRODUCT NET WEIGHT:	30.84kg [67.99lb]
PRODUCT GROSS WEIGHT:	38.86kg [85.67lb]
DIMENSIONS:	L 2,130mm [83.85"] x W 540mm [21.25"] x H 560mm [22.05"]
MIN ACTIVE AREA REQUIRED:	L 2,450mm [96.45"] x W 1,150mm [45.27"]
STORED VERTICAL DIMENSIONS:	L 560mm [22.05"] x W 540mm [21.25"] x H 2,130mm [83.85"]
MAX USER WEIGHT:	150kg [330lb]
COMMERCIAL WARRANTY:	Frame 10 years - Fluid Tank 5 years Mechanical and all other non wearing components - 2 years



## CONSOLE FEATURES

- + Bluetooth Connectivity
- + Auto start
- + Time - Elapsed time
- + Level - Auto to selected resistance level
- + 500M Time - Time to row 500 meters
- + Watt - Unit of power per stroke
- + Distance - Updated every second
- + SPM - Strokes per minute
- + Power Graphs - 2 Options
- + Heart rate - Polar compatible
- + Calories burned per hour

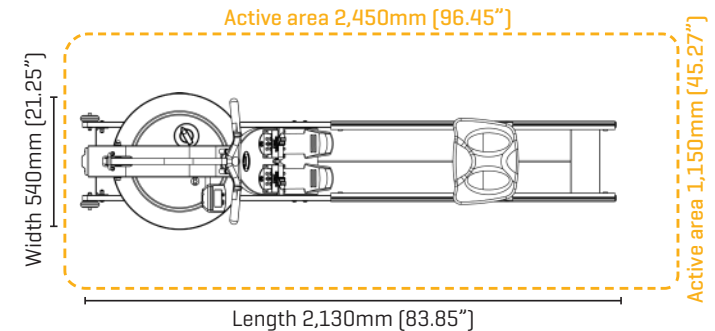

## ABOUT FDF (FIRST DEGREE FITNESS)

FDF is the leader in designing and manufacturing a range of adjustable Fluid Resistance fitness machines for commercial and residential applications. At the heart of the fitness range is our unique and patented Twin Tank Fluid Resistance system. The adjustable Fluid Resistance system challenged the conventional thinking of how water could work to provide adjustable resistance rather than just a liquid mass flywheel. The patented Twin Tank system provides silky smooth resistance at any speed and is perfect for cardio training, warm-ups, cool downs, intense HIIT workouts or rehabilitation programs. FDF categorizes the range of adjustable Fluid Resistance machines under the banners, **FluidRower**, **FluidExercise** and **FluidPowerZone**, see the adjacent web links. FDF products are distributed throughout the globe and are popular in Fitness Centers, Hotels and Apartments, Sporting Clubs, Universities, First Responders, Defence Force Training Facilities and Physical Rehabilitation Clinics.



TOUCH HEART RATE HANDLE



PHONE HOLDER



ELEVATE KIT



SEAT BACK KIT

## OPTIONAL FLUIDROWER ACCESSORIES



View all FDF products at

[FLUIDROWER.com](http://FLUIDROWER.com)

[FLUIDEXERCISE.com](http://FLUIDEXERCISE.com)

[FLUIDPOWERZONE.com](http://FLUIDPOWERZONE.com)

\* FDF reserves the right to modify any product design, manufacture or aesthetic without notice or consultation. Product specifications and warranties may vary from country to country.